

# HP-20EEXIINT

LOUDSPEAKER 20W, 100V, EX ZONE 2



when communication is **critical**

## FEATURES

- Horn speaker in Antistatic polyamide.
- For zone 1 & 2
- 100V line transformer
- Adjustable power tapping: 2,0W - 3,5W, - 7,5W - 15,0W - 20,0W



## INSTALLATION, OPERATION AND MAINTENANCE PROCEDURE

- Unscrew lid (4 screws). Lead cable through cable gland and connect to screw terminal (100V or 70V)
- Tighten cable gland to ensure IP-grade
- Fasten lid with a torque of 2-3 Nm
- Fasten bracket with 1-3 screws
- To change the position of the loudspeaker, please adjust the bracket (by loosening / tightening the screws) as required
- HP-20EEXIINT is designed for Zone 2 environment
- For optimum performance, always use the correct voltage / power and operate within the frequency limits as stated
- Do not open loudspeaker when energized

## SPECIFICATIONS

Material / Color	Anti-static PA / Black
Mounting	Bracket
Termination	Screw terminal
Weight w/transformer	2.3 kg
IP-rating	IP-67
Max. / min. amb. temp	50°C / -50°C
Rated / max. power	20 W / 20 W
SPL 1W/1m	110 dB
SPL rated power	120 dB
Effective freq. range	310 - 8000 Hz
Dispersion (-6dB) 1kHz / 4kHz	115° / 30°
Directivity factor	Q
Options	Impedances, colors, labels

ORDER NUMBER	DESCRIPTION	SHIP WEIGHT
3006100058	HP-20EEXIINT LOUDSPEAKER 20W 100V EX ZONE 2	2.3 KG

## HP-20EEXIINT LOUDSPEAKER 20W, 100V, EX ZONE 2

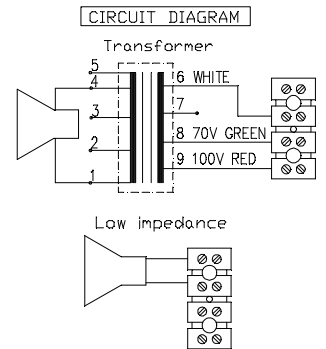
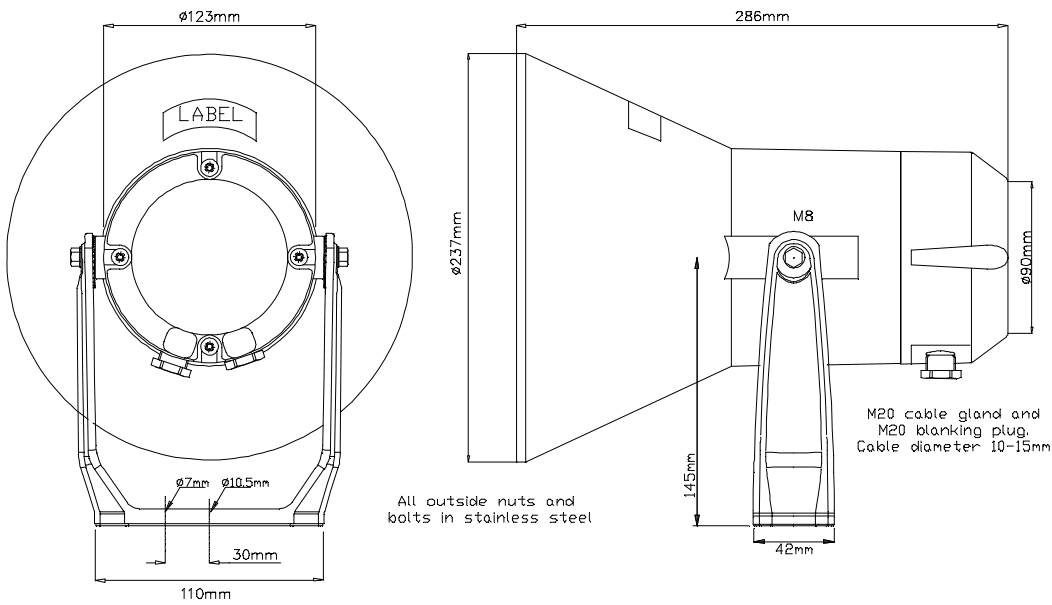

70/100 volt combined transformer  
Primary connections

White : Green 70 V  
White : Red 100 V

Secondary nominal tapings

1 : 4	20 W
1 : 3	15 W
1 : 2	7,5 W
2 : 4	3,5 W
2 : 3	2,0 W

Certified by / Certification code / Number: NEMKO / Ex nA II T3 / 03ATEX3568

